

Räumdorne Nutenbreite 12 mm

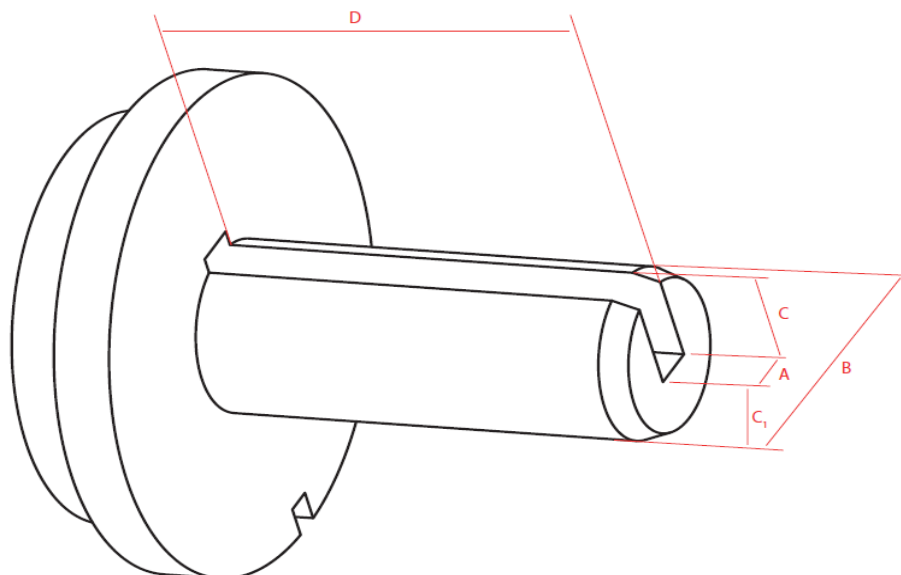

Nummer	Nutenbreite A	Durchmesser B	Dorn-Nutentiefe C	Hilfsmaß Werkzeughöhe C₁	Dornlänge D
DR12 - 18	12 mm	32 mm	21 mm	10,5 mm	190 mm
DR12 - 03	12 mm	34,5 mm	25,5 mm	8 mm	92,5 mm
DR12 - 16	12 mm	35 mm	21,5 mm	13 mm	150 mm
DR12 - 09	12 mm	35 mm	25 mm	9 mm	100 mm
DR12 - 05	12 mm	35 mm	25,5 mm	8,5 mm	101 mm
DR12 - 24	12 mm	38 mm	24 mm	13,5 mm	200 mm
DR12 - 07	12 mm	38 mm	25 mm	12,5 mm	104 mm
DR12 - 17	12 mm	38 mm	25 mm	12,5 mm	151 mm
DR12 - 01	12 mm	39 mm	25,5 mm	13 mm	100 mm
DR12 - 21	12 mm	40 mm	25 mm	14 mm	150 mm
DR12 - 22	12 mm	40 mm	25 mm	14,5 mm	184 mm
DR12 - 23	12 mm	40 mm	20 mm	19,5 mm	200 mm
DR12 - 14	12 mm	40 mm	26 mm	13,5 mm	76 mm
DR12 - 04	12 mm	40 mm	28 mm	11,5 mm	100 mm
DR12 - 02	12 mm	42 mm	24,5 mm	17 mm	93 mm
DR12 - 19	12 mm	42 mm	25 mm	16 mm	140 mm
DR12 - 12	12 mm	42 mm	27 mm	14,5 mm	93 mm
DR12 - 15	12 mm	42 mm	27,5 mm	14 mm	93,5 mm
DR12 - 06	12 mm	42 mm	28 mm	13,5 mm	80 mm
DR12 - 11	12 mm	45 mm	25 mm	19,5 mm	92,5 mm
DR12 - 10	12 mm	45 mm	27 mm	17,5 mm	80 mm
DR12 - 08	12 mm	45 mm	27,5 mm	17 mm	93 mm
DR12 - 20	12 mm	47 mm	25 mm	21,5 mm	150 mm
DR12 - 13	12 mm	50 mm	26,5 mm	23 mm	93,5 mm
DR12 - 25	12 mm	50 mm	28,5 mm	21 mm	223 mm
DR12 - 26	12 mm	80 mm	36 mm	43,5 mm	101 mm

