

Räumdorne Nutenbreite 16 mm

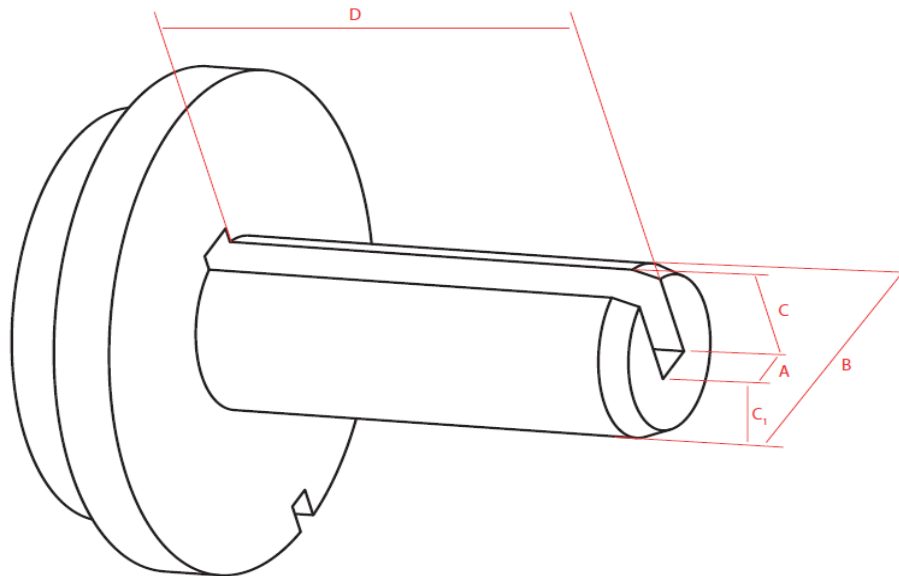

Nummer	Nutenbreite A	Durchmesser B	Dorn- Nutentiefe C	Hilfsmaß Werkzeughöhe C₁	Dornlänge D
DR16 - 01	16 mm	50 mm	32,5 mm	16 mm	100 mm
DR16 - 05	16 mm	50 mm	32 mm	17 mm	200 mm
DR16 - 06	16 mm	50 mm	32 mm	17 mm	203 mm
DR16 - 08	16 mm	50 mm	30 mm	20 mm	200 mm
DR16 - 02	16 mm	53 mm	30 mm	21,5 mm	100 mm
DR16 - 03	16 mm	63,5 mm	31,5 mm	31,5 mm	85 mm
DR16 - 04	16 mm	68 mm	31,85 mm	35 mm	111 mm